

# CAT® C13D

U.S. EPA TIER 4 FINAL/EU STAGE V/CHINA NONROAD STAGE IV/  
JAPAN 2014/KOREA STAGE V

340-515 KW (456-690 HP)

INDUSTRIAL POWER UNIT (IPU)



The Cat® C13D IPU configuration not only provides the flexibility and options found on a standard industrial engine, but also comes fitted with full aftertreatment and mounting, an integrated cooling system with air and coolant lines, and full wire harnessing with an engine-mounted ECM. Meeting U.S. EPA Tier 4 Final, EU Stage V and other equivalent emissions standards, the IPU allows for easier and faster installation, allowing the customer to spend less time worrying about integration and more time doing the work that matters.

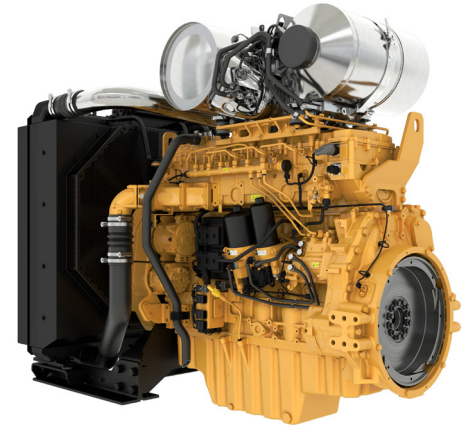

## FEATURES AND BENEFITS

### Full Packaged Installation

The IPU is an example of an industrial configuration that has the aftertreatment system, the cooling pack, the fuel filter module, and the entire wiring harness all pre-mounted on the engine right out of the factory. Furthermore, a control panel and telematics unit can be added on for an even more complete package.

### Reliable, Quiet and Durable Power

A quiet engine is not only safer, but it also cuts down on job site noise pollution – especially in areas where decibel limitations are enforced. With proven technologies such as rear gear train architecture and high-pressure common rail fuel injection, your Cat® powered equipment is made to run quietly while you work.

### World-Class Product Support Offered Through Cat® Dealer Network

Our network of Cat dealers across the globe means no matter where you are, help is close by. And because our engines are covered by warranty, you can feel good about your purchase being protected. With programs like extended service coverage and customer value agreements, you can choose to continue your Cat engine's protection for the life of your machine.

## SPECIFICATION

Cylinders	6 vertical in-line
Displacement, L (in <sup>3</sup> )	12.9 (787.2)
Aspiration	Turbocharged aftercooled
Bore and stroke, mm (in)	130 x 162 (5.1 x 6.4)
Maximum power, kW (hp)	515 (690)
Rated speed, rpm	1800 - 2100
Maximum torque, Nm (lb ft) @ rpm	3200 (2360) @ 1300
Combustion system	Direct injection
Weight, kg (lb)	1749 (3856)
Rotation (viewed from flywheel)	Anti-clockwise

For additional information on all your power requirements, visit [www.cat-industrial.com](http://www.cat-industrial.com)

All information in this document is substantially correct at time of printing and may be altered subsequently.  
Photographs are for illustrative purposes only and may not reflect final specification.  
Final weight and dimensions will depend on completed specification.  
Information subject to selected configuration, and subject to change without notice.  
Engine power measured per ISO 14396:2002

AEXJ0141-01 (12-22)

© Caterpillar. All Rights Reserved. CAT, CATERPILLAR, LET'S DO THE WORK, their respective logos, "Caterpillar Corporate Yellow", the "Power Edge" and Cat "Modern Hex" trade dress as well as corporate and product identity used herein, are trademarks of Caterpillar and may not be used without permission.

# CAT® C13D

U.S. EPA TIER 4 FINAL/EU STAGE V/CHINA NONROAD STAGE IV/  
JAPAN 2014/KOREA STAGE V

340-515 KW (456-690 HP)

INDUSTRIAL POWER UNIT (IPU)

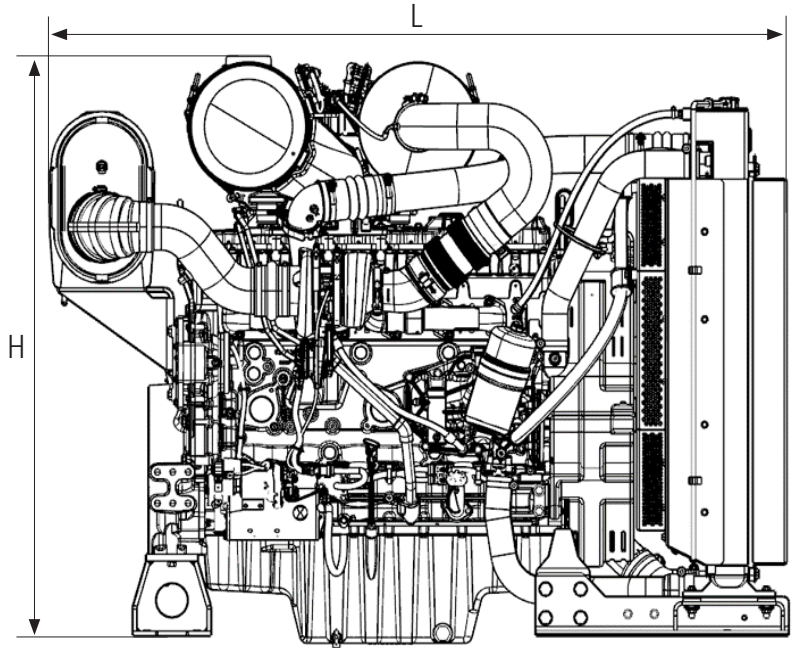
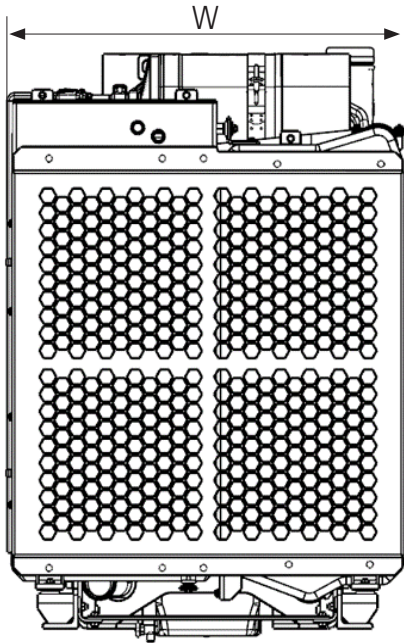
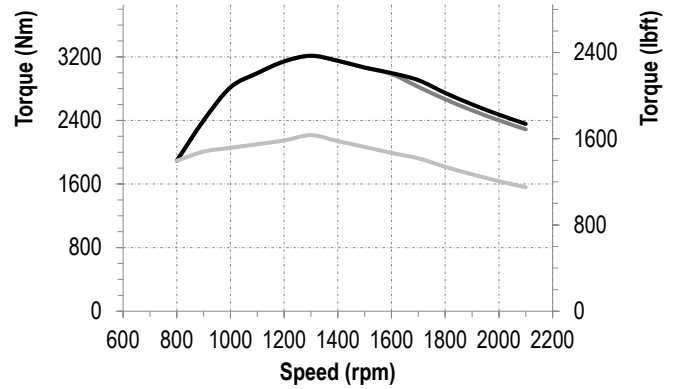
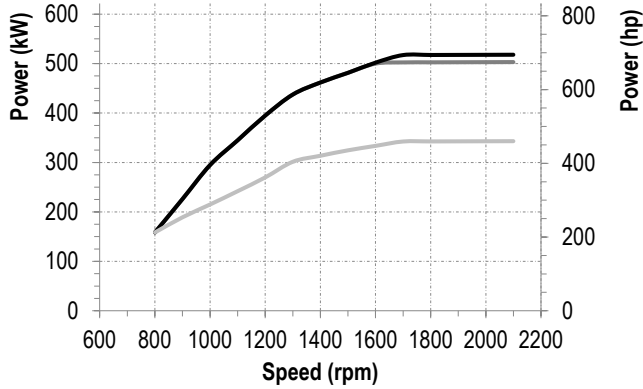

## DIMENSIONS AND WEIGHT

Length, mm (in)	2249 (89)
Width, mm (in)	1160 (46)
Height, mm (in)	1641 (65)
Weight, kg (lb)	1749 (3856)

For additional information on all your power requirements, visit [www.cat-industrial.com](http://www.cat-industrial.com)

All information in this document is substantially correct at time of printing and may be altered subsequently. Photographs are for illustrative purposes only and may not reflect final specification. Final weight and dimensions will depend on completed specification. Information subject to selected configuration, and subject to change without notice. Engine power measured per ISO 14396:2002

AEXJ0141-01 (12-22)

© Caterpillar. All Rights Reserved. CAT, CATERPILLAR, LET'S DO THE WORK, their respective logos, "Caterpillar Corporate Yellow", the "Power Edge" and Cat "Modern Hex" trade dress as well as corporate and product identity used herein, are trademarks of Caterpillar and may not be used without permission.