



**Prime 310 kVA (248 kW)
50/60 Hz Switchable
EU Stage V**

Image shown may not reflect actual configuration

Specifications

Frequency (Hz)	Speed (rpm)	Voltage	Prime		Output Amps (A)	Breaker Rating (A)
			kVA	kW		
50	1500	415 / 240 V	310	248	431	630
		400 / 230 V	310	248	447	
		380 / 220 V	310	248	471	
60	1800	480 / 277 V	310	248	373	630
		440 / 254 V	310	248	407	
		380 / 220 V	310	248	471	
		240 / 139 V	N/A	N/A	N/A	N/A
		220 / 127 V	N/A	N/A	N/A	

Cat® C9.3B Diesel Engine	Metric	Imperial (English)
Configuration	Inline 6-cylinder, 4-Stroke-Cycle, Water Cooled, Diesel	
Bore	115 mm	4.53 in
Stroke	149 mm	5.87 in
Displacement	9.3 L	567.5 in ³
Aspiration	Turbocharged-Aftercooled (TA)	
Compression Ratio	17.0:1	
Engine rpm	1500-1800	
Aftercooler Type	ATAAC	
Turbocharger	Single	
Fuel System	Direct Injection	
Governor Type	Electronic ECM controlled (A6E2)	
Fuel	See Fuel Specification Table	

Standard Equipment

Generator

- LC5114N frame; 3-phase random wound, 12 lead, self-excited, 2/3 pitch
- Coastal insulation protection (CIP)

Cat® C9.3B Diesel Engine

- Turbocharged, air-to-air aftercooler
- Electronic ECM control

After Treatment

- Engine Mounted Clean Emissions Module (CEM)
- Diesel Emissions Fluid (DEF) Tank located in discharge box, accessible through lockable access door

Air Filter

- High Efficiency two stage air cleaner, with service indicator

Cooling System

- Variable speed fan
- Package mounted radiator with vertical air discharge
- High ambient performance
- Fully guarded pusher fan
- Low coolant level shutdown
- 50% glycol mix with corrosion inhibitor

Charging System

- Charging alternator; 24V, heavy duty with integral regulator and belt guards

Starting System

- Single 24V electric starting motor

Fuel System

- 12hr dual wall fuel tank (based on 75% Prime load)
- Internal fuel fill
- Engine mounted primary and secondary fuel filter
 - Primary filter (10 micron) with integral water separator (330ml capacity)
 - Secondary filter (4 micron)
- Automatic onboard priming pump
- Mechanical fuel gauge

Control Panel

- EMCP 4.2B set mounted digital controller
- 50/60Hz frequency switch (via terminal link)
- IVR with EM10 excitation module
- Panel & enclosure mounted emergency stop

Distribution System

- Separate robust steel enclosures for control & distribution sections
- Distribution door protected with 24V DC shunt trip safety switch
- 4 pole, 630A main circuit breaker
- Two-wire remote start/stop terminals and AC aux power connection for rapid starting

Mounting System

- Heavy duty steel baseframe with integral fuel tank (dual wall)
- Provides 110% spill containment including all on-board fluids
- Forklift pockets
- Skid plates with drag points
- Generator set soft mounted using captive vibration mounts

Enclosure

- Sound attenuating, galvanised sheet steel enclosure with exceptional noise reduction performance
- Interior walls, ceilings and ducts insulated with precision cut noise insulating materials
- Sealed quarter-turn compression latches with key or padlock capabilities
- External side-mounted dual point lifting frame for improved hook access
- Powder coated with Cat Rental Power decals

Exhaust System

- Certified spark arresting system
- Outlet box mounted with vertical discharge

Lube Oil System

- On-engine primary and secondary oil filters, dipstick and oil filler
- Closed crankcase breather
- 500 hour oil change requirement

General

- Factory Tested
- Full manufacturer's warranty, O&M manuals



Fuel Specifications

Specification Standard	Grade Class	Fuel Description
EN 590	Grade A to F & Class 0 to 4	European automotive fuel (DERV)
ASTM D975	1-D S15	U.S. special purpose light middle distillate
		15ppm sulphur
ASTM D975	2-D S15	U.S. special purpose light middle distillate
		15ppm sulphur
JIS K2204	No. 1	Japanese automotive diesel. Different classes correspond to season and district where used
	No. 2	
	No. 3	
	Special No. 3	
BS 2869	Class A2	Fuel oil for agriculture and industrial engines (red diesel)
MIL-DTL-83133 NATO F34	JP-8	Aviation kerosene fuels - acceptable when used with appropriate lubricity additive, and must meet minimum requirements of Caterpillar Specification for Diesel Fuel. The lubricity of these fuels must not exceed wear scar diameter of 0.52mm (0.02047 in) as per ISO 12156-1
MIL-DTL-83133 NATO F35		
MIL-DTL-5624 NATO F44	JP-5	
MIL-DTL-38219 (USAF)	JP-7	
NATO XF63		
ASTM D1655	JET A	
	JET A1	
B5-B7		Blend of biodiesel meeting EN 14214 or ASTM D6751 with EN 590 or ASTM D975 standard mineral diesel fuels.
B7-B20		
EU Stage V specifies Ultra Low Sulphur Diesel		<p>Ultra Low Sulphur Diesel Only (ULSD) ULSD with a maximum fuel sulphur level of either 15 or 20 ppm¹ is required in all diesel applications using a diesel particulate filter (DPF and DOC).</p> <p>Bio-diesel fuel may be used up to B20 (80% standard ULSD with 20% bio-fuel dilution by volume), provided an appropriate approved additive is used</p>

Oil Specifications

Specification Standard	Oil Description
EU Stage V Recommended oil 15W-40 CK-4 1E1867F	Minimum spec 15W-40 CJ-4 1E1867E

DEF Specifications

Specification Standard	DEF Description
EU Stage V DEF Requirements ISO22241-1	European automotive fuel (DERV)



Technical Data

Cat® Generator	
Frame size	LC5114N
Pitch	2/3
No. of poles	4
Excitation	Static regulated, brushless, self excited
Number of bearings	Single bearing, close coupled
Insulation	Class H
Temperature rise	125/40°C
Enclosure	Drip proof IP23
Overspeed capability — % of rated	25%
Voltage regulator	3-phase sensing with adjustable volts per hertz
Voltage regulation	Less than ± 0.5%
Wave form deviation	
Telephone Influence Factor (TIF)	Less than 2%
Harmonic Distortion (THD)	Less than 2%

Cat Generator Set			
	TMI Performance No. Units	Prime — 50 Hz EM4733	Prime — 60 Hz EM4735
Power Rating	kVA (kW)	310 (248)	310 (248)
Performance Specification			
Lubricating System Oil pan capacity	L (gal)	30 (7.9)	
Fuel System Fuel consumption — 100% Load	L/hr (gal/hr)	67.1 (17.7)	77.4 (20.4)
75% Load	L/hr (gal/hr)	50 (13.2)	56.5 (14.9)
50% Load	L/hr (gal/hr)	34.2 (9)	39 (10.3)
Fuel tank capacity	L (gal)	667 (176)	
Running time @ 75% rating	Hr	13.3	11.8
After Treatment* DEF Tank Capacity	L (gal)	65.6 (17.3)	
Cooling System Ambient capability	°C (°F)	36 (97)	47 (117)
Engine & radiator coolant capacity	L (gal)	37.9 (10)	37.9 (10)
Engine coolant capacity	L (gal)	20.3 (5.4)	20.3 (5.4)
Air Requirements Combustion air flow	m³/min (cfm)	19 (671)	24 (847.5)
Exhaust System Exhaust flow at rated — dry exhaust	m³/min (cfm)	39 (1377)	45 (1589)
Exhaust temperature at rated kW	°C (°F)	434 (813)	413 (775)

*DEF consumption is on average approximately 4% of the fuel consumption



Technical Data (continued)

Cat Generator Set			
	TMI Performance No. Units	Prime — 50 Hz EM4733	Prime — 60 Hz EM4735
Noise Rating (with enclosure) ** Sound Power*			
@ 7 meters @ 75% load	dB(A)	TBC	TBC
@ 7 meters @ 100% load	dB(A)	TBC	TBC
@ 1 meters @ 75% load	dB(A)	TBC	TBC
@ 1 meter @ 100% load	dB(A)	TBC	TBC
Emissions data at 100% Load			
Nox	g/hp-hr	0.05	0.07
CO	g/hp-hr	0.05	0.07
HC	g/hp-hr	0.01	0.02
PM	g/hp-hr	0.00	0.00

**Guaranteed sound power as per 2000/14/EC

For full Engine & Emissions data please refer to TMI using the engine performance no.

Dimensions			
	Length mm (in)	Width mm (in)	Height mm (in)
Generator Set	4085 (161)	1514 (60)	2277 (90)

Weight	
	Weight — kg (lb)
Lube Oil & Coolant — Empty Fuel Tank	4103 (9046)
Full Fuel Tank	4784 (10547)

Sockets	15A	16A	32A	50A	63A	125A
CEE Form*	-	2x1ph+N+E	2x3ph+N+E	-	1x3ph+N+E	1x3ph+N+E

*Busbar connection is standard. Distribution sockets are optional.

Layout for General Dimensions

Dimensions in millimeters (inches)

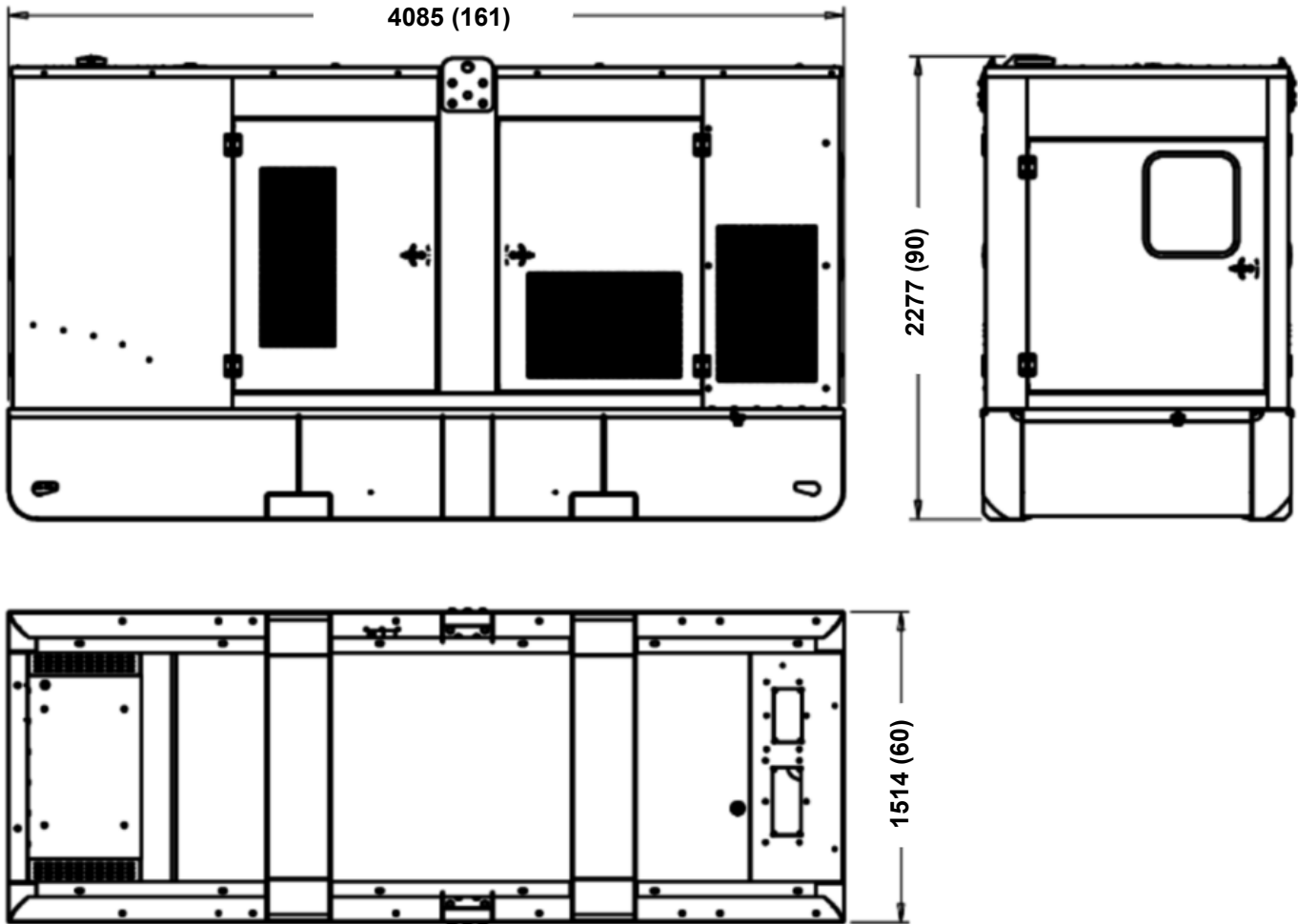

Control Panel and Power Distribution Layout

Item	Description
1	Steel enclosure with hinged, lockable door (not shown)
2	EMCP 4.2B digital genset controller
3	Emergency Stop button
4	Alarm
5	Service tool connector
6	Circuit breaker. 4-pole molded case, 630A
7	Main bus connection (bus bars with 14 mm holes)
8	Micro safety switch for bus bar door
9	Manual holder
10	Emission system failure lamp
11	Low DEF level lamp

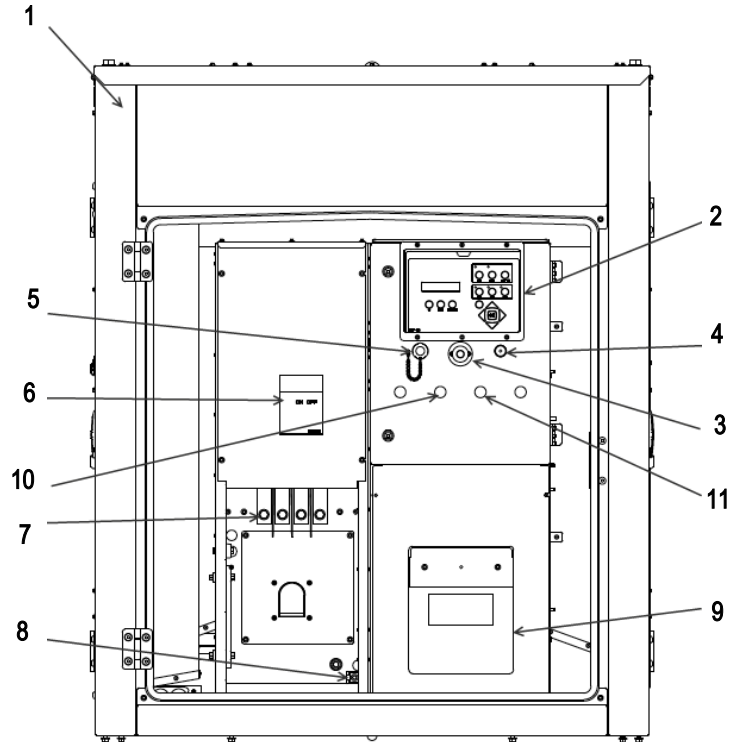

Rating Definitions and Conditions

Designed to Meet Specifications: ISO 8528, EN 12601, EN 60204-1, ISO 3046, IEC 60034.

Ratings are based on SAE J1349 standard conditions. These ratings also apply at ISO3046 standard conditions.

Prime — Output available with varying load for an unlimited time. Average power output is 70% of the prime power rating. Typical peak demand is 100% of prime rated kW with 10% overload capability for emergency use for a maximum of 1 hour in 12. Overload operation cannot exceed 25 hours per year.

Fuel rates are based on fuel oil of 35° API [16°C (60°F)] gravity having an LHV of 42 780 kJ/kg (18,390 Btu/lb) when used at 29°C (85°F) and weighing 838.9 g/liter (7.001 lbs/U.S. gal).

Additional ratings may be available for specific customer requirements, contact your Cat representative for details. For information regarding low sulfur fuel and biodiesel capability, please consult your Cat dealer.

www.Cat.com/rentalpower

©2021 Caterpillar
All rights reserved.

Materials and specifications are subject to change without notice. The International System of Units (SI) is used in this publication.

CAT, CATERPILLAR, LET'S DO THE WORK, their respective logos, "Caterpillar Corporate Yellow", the "Power Edge" and Cat "Modern Hex" trade dress as well as corporate and product identity used herein, are trademarks of Caterpillar and may not be used without permission.